

ECO-PERF VENTED FASCIA

INSTALLATION INSTRUCTIONS

U.S. PATENT # 8,069,619 B1
AND # 7,721,489 B1

DETAIL A

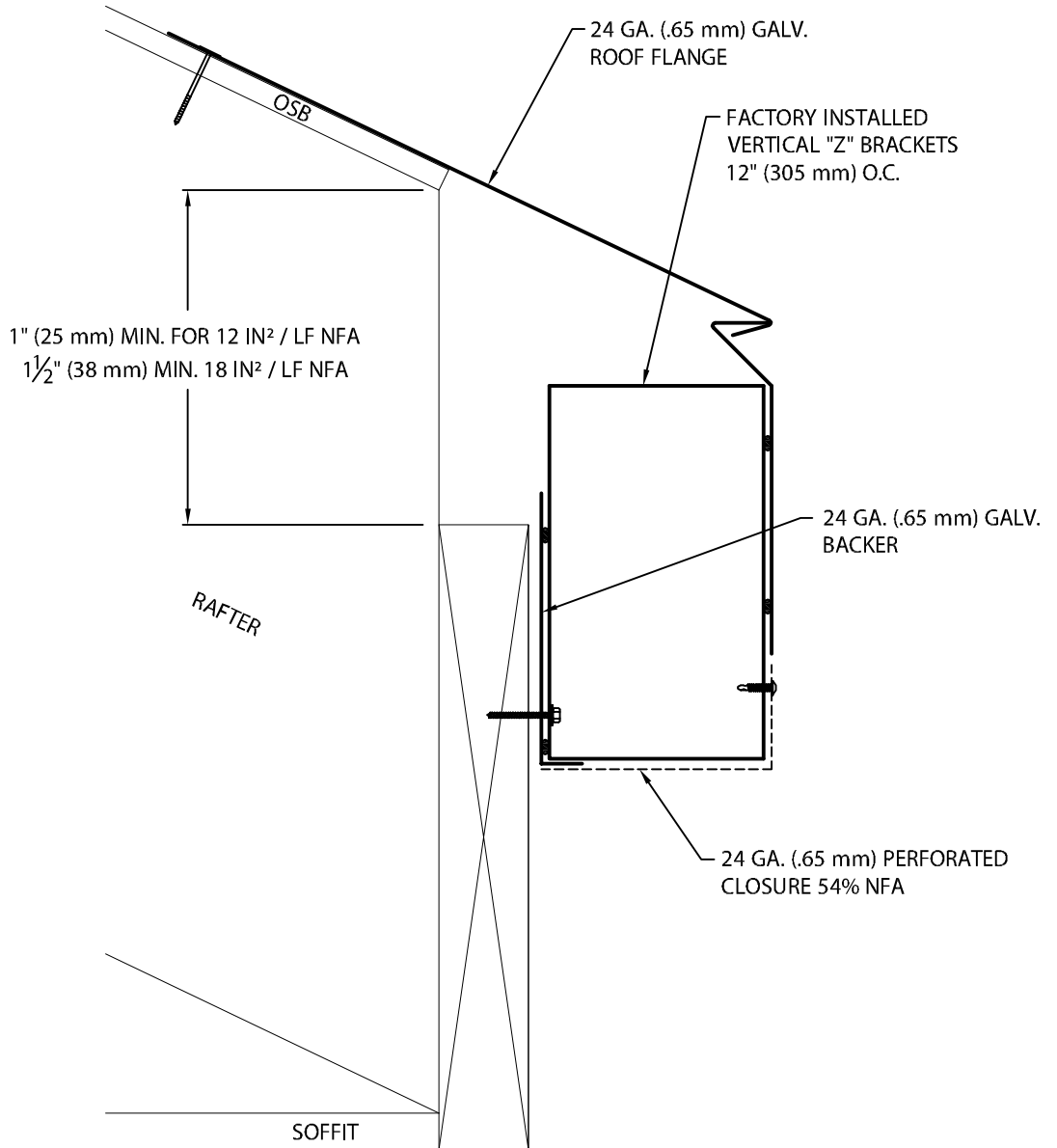

SUBSTRATE MUST BE CONTINUOUS, FLAT, VERTICAL, AND ABLE TO SUPPORT FASTENERS WITH A MINIMUM 240 LB. PULL-OUT.



Phone: 800-558-2162
Fax: 800-770-3934
www.metalera.com

DATE: 05/09/12

SHT.# 1 OF 6

DRN BY: JJC

CKD BY: SAK

DWG# 31127-14647

F

ECO-PERF VENTED FASCIA

INSTALLATION INSTRUCTIONS

U.S. PATENT # 8,069,619 B1
AND # 7,721,489 B1

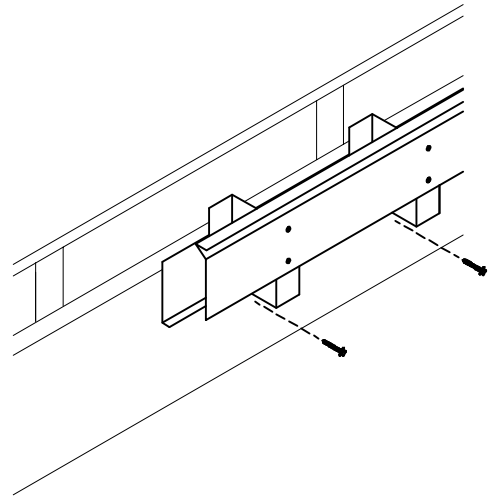
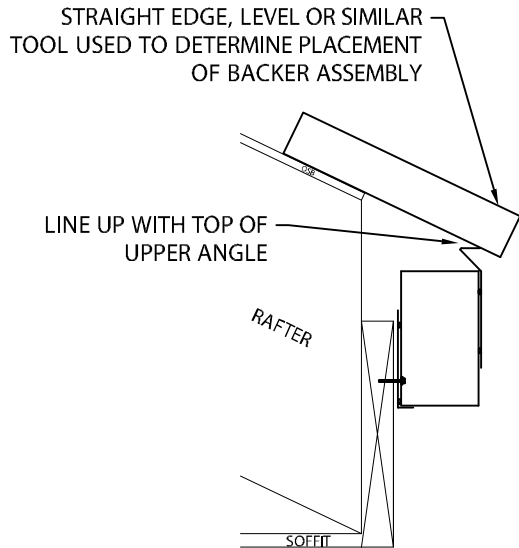

1. BACKER ASSEMBLY ATTACHMENT

PLACE A STRAIGHT EDGE, LEVEL OR SIMILAR TOOL ON ROOF AS SHOWN TO DETERMINE PLACEMENT OF BACKER ASSEMBLY. STRAIGHT EDGE WILL LINE UP WITH THE TOP OF THE UPPER ANGLE OF BACKER ASSEMBLY. ATTACH THE BACKER ASSEMBLY THROUGH THE VERTICAL "Z" BRACKETS AND BACKER USING APPROPRIATE FASTENER FOR SUBSTRATE ON EVERY VERTICAL "Z" BRACKET. NOTE: BIT OR DRIVER EXTENSION MAY BE NEEDED.

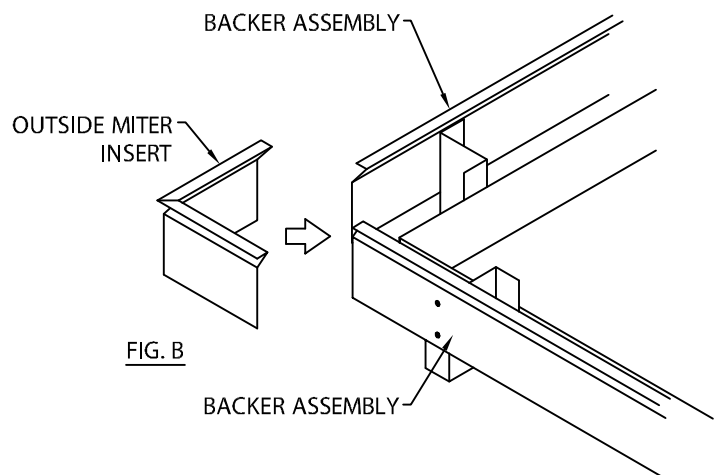
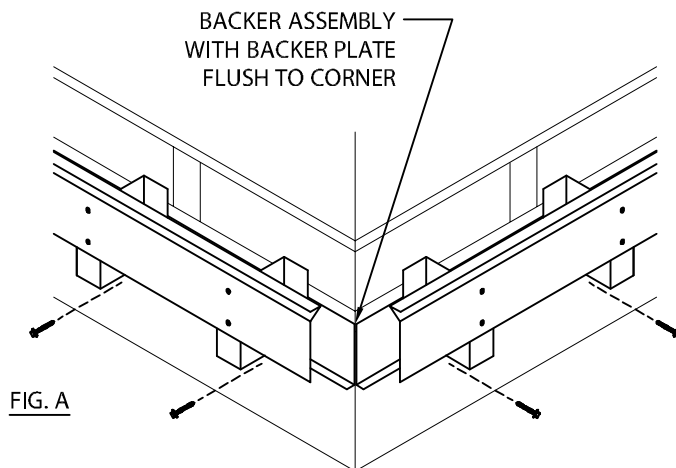

2. OUTSIDE CORNERS

ATTACH BACKER ASSEMBLIES SO THAT THE BACKER PLATE IS FLUSH TO THE CORNER ON BOTH SIDES (FIG. A). PLACE OUTSIDE MITER INSERT (FIG. B) AGAINST ASSEMBLY AS SHOWN AND FASTEN INTO PLACE WITH APPROPRIATE FASTENERS.



Phone: 800-558-2162
Fax: 800-770-3934
www.metalera.com

DATE: 05/09/12

SHT.# 2 OF 6

DRN BY: JJC

CKD BY: SAK

DWG# 31127-14647

F

ECO-PERF VENTED FASCIA

INSTALLATION INSTRUCTIONS

U.S. PATENT # 8,069,619 B1
AND # 7,721,489 B1

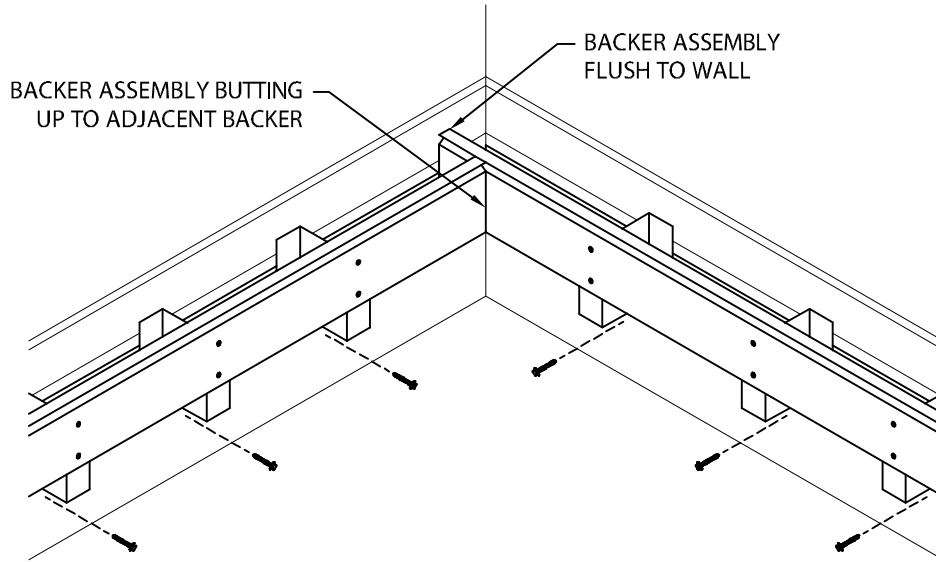

3. INSIDE CORNERS

ATTACH ONE LENGTH OF BACKER ASSEMBLY FLUSH TO WALL AT INSIDE CORNER. BUTT A SECOND BACKER ASSEMBLY AGAINST THAT ONE AND ATTACH IT TO SUBSTRATE.

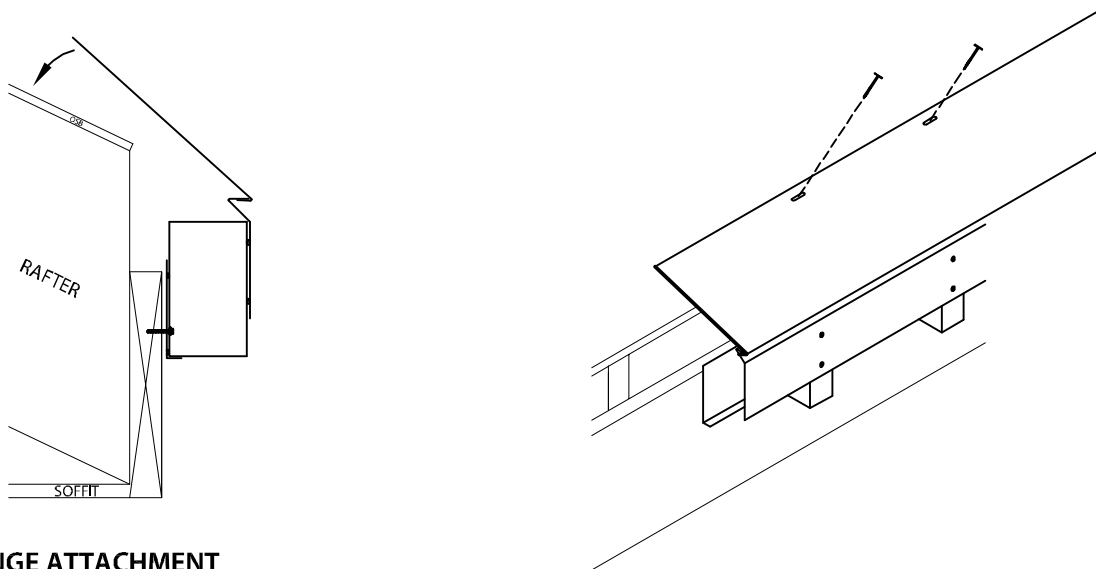

4. ROOF FLANGE ATTACHMENT

HOOK ROOF FLANGE ONTO UPPER ANGLE AND ROTATE INTO PLACE. ATTACH THE ROOF FLANGE TO THE TOP OF THE SHEATHING WITH APPROPRIATE FASTENERS FOR THE SUBSTRATE USING THE PRE-SLOTTED $\frac{5}{32}$ " (4 mm) x $\frac{1}{2}$ " (13 mm) HOLES AT 12" (305 mm) O.C. FIELD FABRICATE ROOF FLANGE MITERS AT CORNERS.



Phone: 800-558-2162
Fax: 800-770-3934
www.metalera.com

DATE: 05/09/12

SHT.# 3 OF 6

DRN BY: JJC

CKD BY: SAK

DWG# 31127-14647

F

ECO-PERF VENTED FASCIA

INSTALLATION INSTRUCTIONS

U.S. PATENT # 8,069,619 B1
AND # 7,721,489 B1

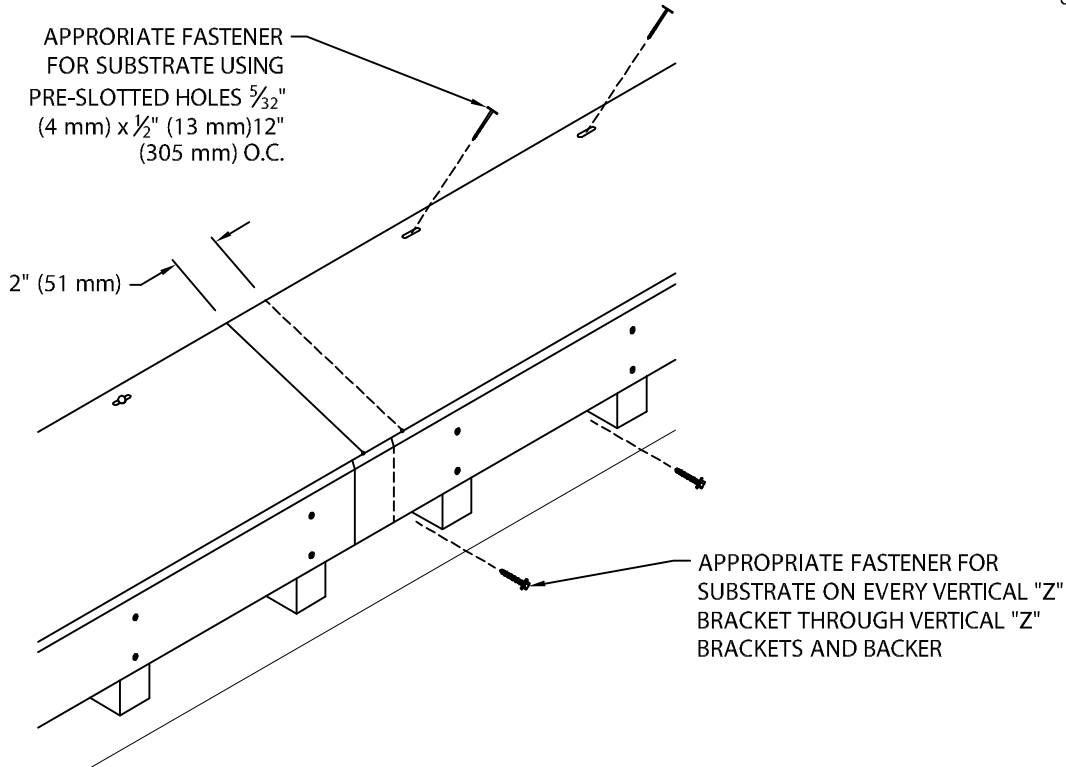

5. BACKER ASSEMBLY LAP JOINT

LAP ONE 12'-0" (3.65 m) PIECE OF BACKER ASSEMBLY 2" (51 mm) OVER THE INSTALLED BACKER ASSEMBLY AS SHOWN. NO FASTENERS ARE NECESSARY AT THE LAP JOINT. INSTALL 12'-0" (3.65 m) BACKER ASSEMBLY AND ROOF FLANGE AS SHOWN IN STEPS 1 AND 2.

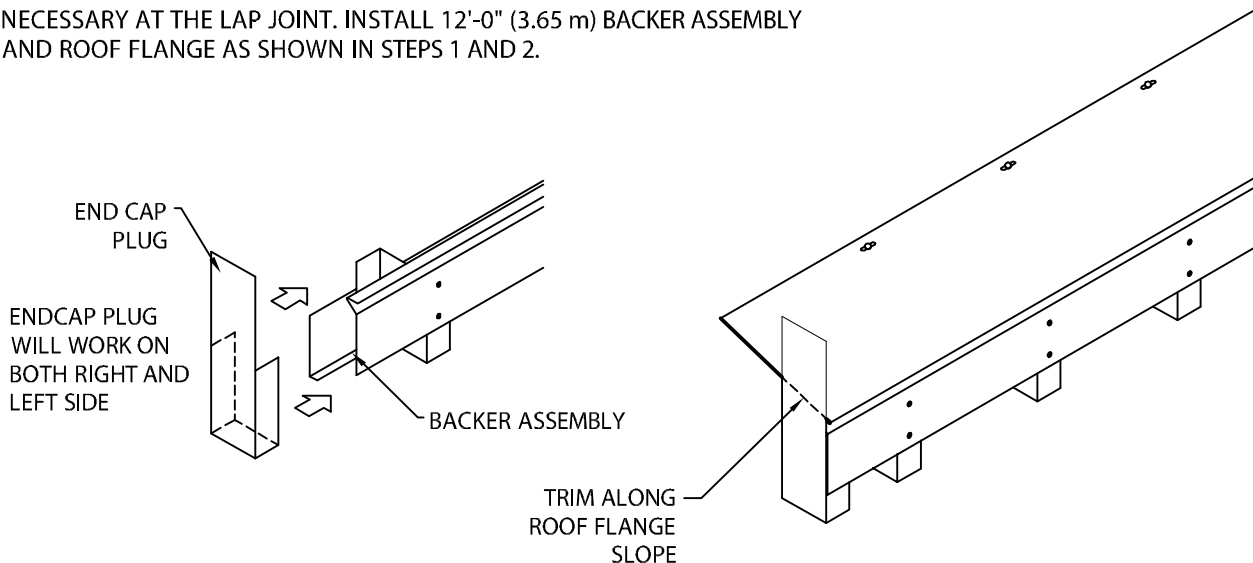

6. ENDCAP PLUG

SLIDE ENDCAP PLUG INTO END OF BACKER ASSEMBLY. FIELD CUT ENDCAP ALONG ROOF FLANGE SLOPE USING A FINE TOOTH HACKSAW OR SNIPS. ENDCAP PLUG CAN BE USED ON EITHER RIGHT OR LEFT SIDE.



Phone: 800-558-2162
Fax: 800-770-3934
www.metalera.com

DATE: 05/09/12

SHT.# 4 OF 6

DRN BY: JJC

CKD BY: SAK

DWG# 31127-14647

F

ECO-PERF VENTED FASCIA

INSTALLATION INSTRUCTIONS

U.S. PATENT # 8,069,619 B1
AND # 7,721,489 B1

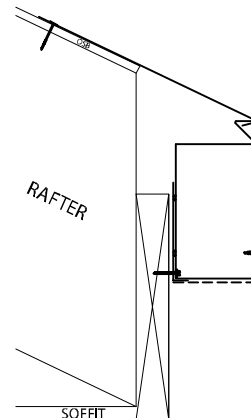
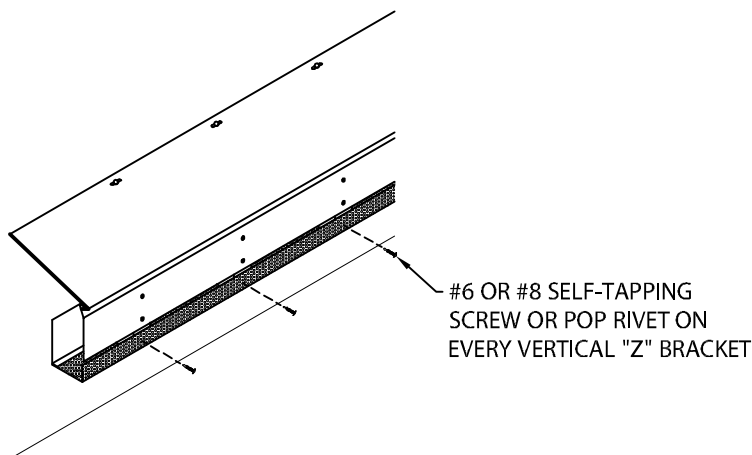

7. PERFORATED CLOSURE ATTACHMENT

ALIGN A 12'-0" (3.65 m) PIECE OF PERFORATED CLOSURE WITH THE BOTTOM OF THE BACKER ASSEMBLY. FASTEN THE FRONT OF THE PERFORATED CLOSURE TO EVERY VERTICAL "Z" BRACKET USING #6 OR #8 SELF-TAPPING SCREW OR POP RIVET. FIELD FABRICATE PERFORATED CLOSURE MITERS AT CORNERS.

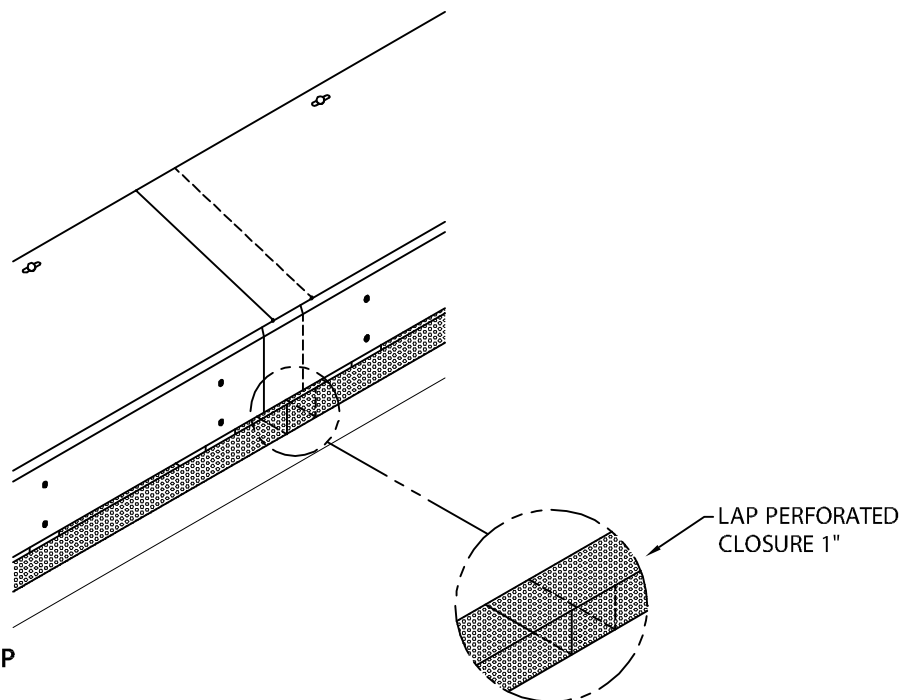

8. PERFORATED CLOSURE LAP

LAP ONE 12'-0" (3.65 m) PIECE OF PERFORATED CLOSURE 1" (25 mm) OVER THE PIECE OF PERFORATED CLOSURE ALREADY INSTALLED AS SHOWN. NO FASTENERS NECESSARY AT LAP JOINT.



Phone: 800-558-2162
Fax: 800-770-3934
www.metalera.com

DATE: 05/09/12	SHT.# 5 OF 6
DRN BY: JJC	DWG# 31127-14647 F
CKD BY: SAK	

ECO-PERF VENTED FASCIA

INSTALLATION INSTRUCTIONS

U.S. PATENT # 8,069,619 B1
AND # 7,721,489 B1

TYPICAL COMPONENT LIST

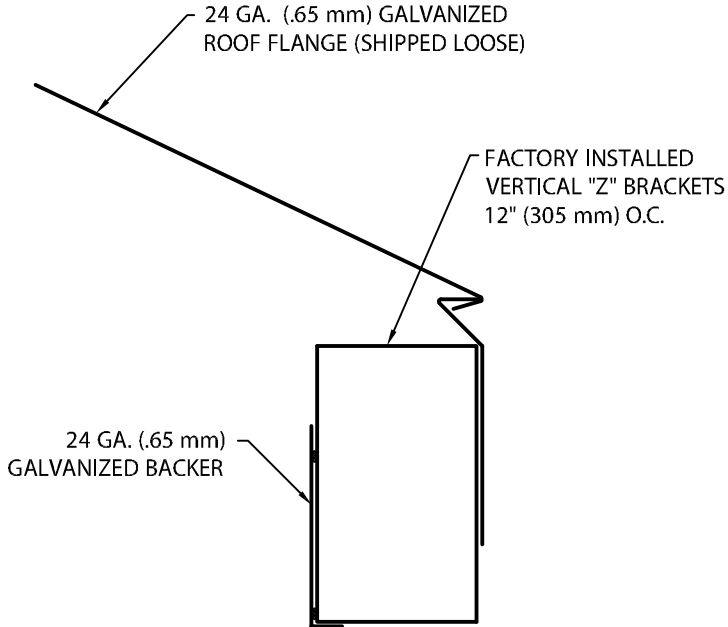

BACKER ASSEMBLY
12'-0" (3.65 m) LENGTHS:
FACTORY ASSEMBLED 24 GA. (.65 mm) GALV. BACKER,
VERTICAL "Z" BRACKETS 12" (51 mm) O.C. AND
24 GA. (.65 mm) GALV. ROOF FLANGE (SHIPPED LOOSE)



**24 GA. (.65 mm)
PERFORATED CLOSURE,
12'-0" (3.65 m) LENGTHS
(SHIPPED LOOSE)**

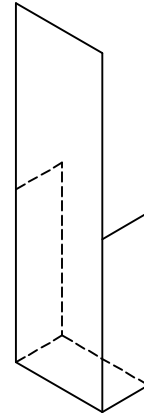

**24 GA. (.65 mm)
ENDCAP PLUG
(SHIPPED LOOSE)**

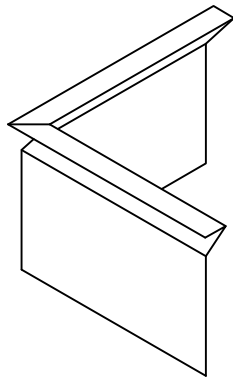

**24 GA. (.65 mm)
OUTSIDE MITER INSERT
(SHIPPED LOOSE)**



Phone: 800-558-2162
Fax: 800-770-3934
www.metalera.com

DATE: 05/09/12	SHT.# 6 OF 6
DRN BY: JJC	DWG# 31127-14647 F
CKD BY: SAK	