



310 Quadral Dr. Wadsworth, OH 44281  
Phone: (800) 356-3521  
[www.soprema.us](http://www.soprema.us)

## INSTALLATION INSTRUCTION FOR SOPRA-TITE GOLD COPING

### APPROVALS\*

ANSI/SPRI/FM 4435/ES-1



MIAMI-DADE COUNTY  
APPROVED

\*MAXIMUM TESTED DIMENSIONS: INSIDE FACE: 4" | OUTSIDE FACE: 6" | WALL WIDTH: 16"

DATE: 12/04/24 | DRN BY: MLM | CKD BY: MM | DWG #: 33111-44336 | REV. A

## **TABLE OF CONTENTS**

<b>Overview of Coping Versions .....</b>	<b>Page 3</b>
<b>Substrate and Fastener Information .....</b>	<b>Page 4</b>
<b>Anchor Clip Spacing .....</b>	<b>Page 4</b>
<b>Standard Installation Steps .....</b> <b>(Including Standard Accessories)</b>	<b>Page 5-7</b>
<b>Radius Coping Installation Steps .....</b>	<b>Page 8</b>

# SOPRA-TITE GOLD COPING

## COPING VERSIONS

### TAPERED

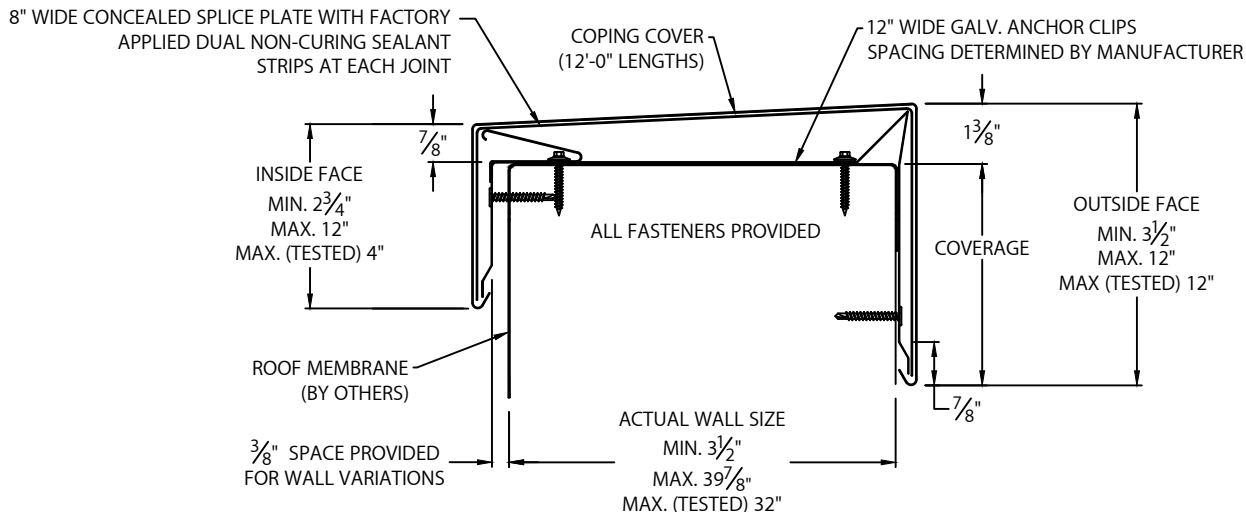

### FLAT

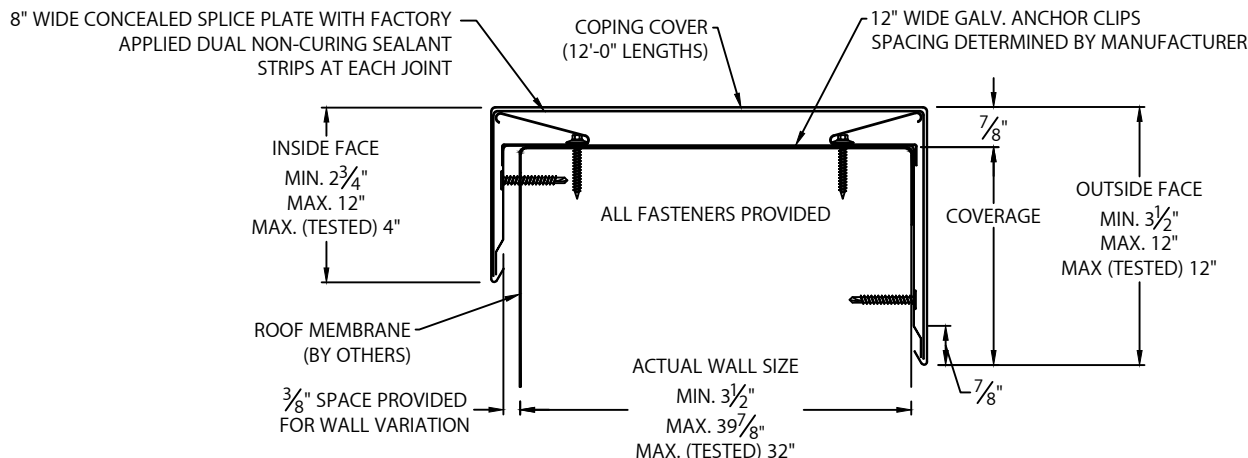

### EXISTING SLOPE

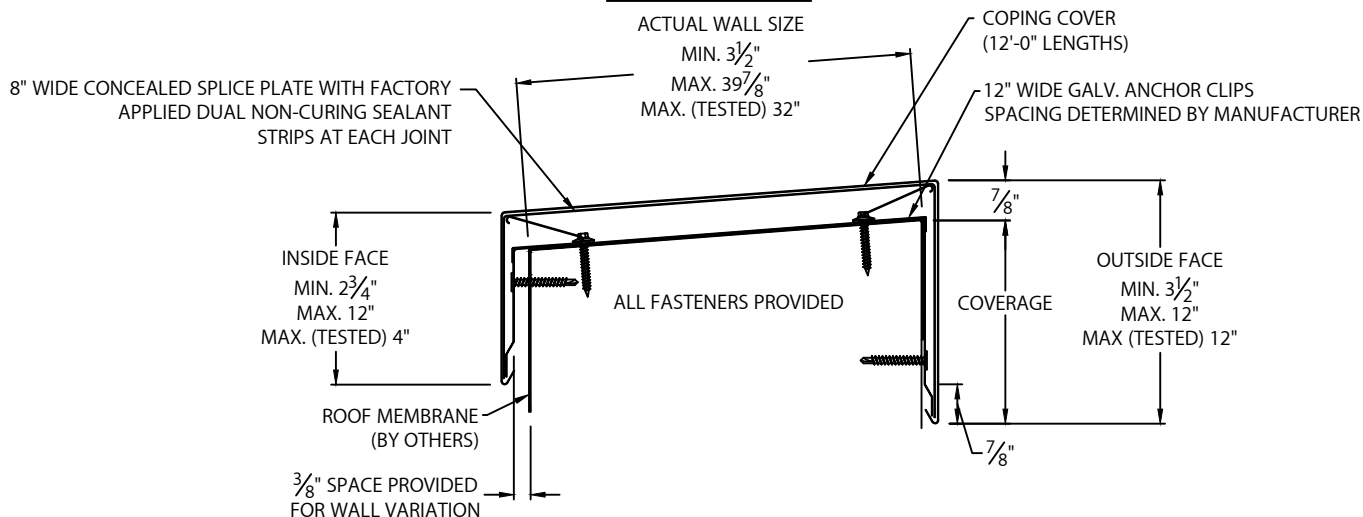

800-356-3521  
www.soprema.us

310 Quadral Dr.  
Wadsworth, OH 44281  
f: 330-334-6257

DATE: 12/04/24  
DRN BY: MLM  
CKD BY: MM

SHT.# 3 OF 8  
DWG# 33111-44336

A

# SOPRA-TITE GOLD COPING

## FASTENERS AND ANCHOR CLIP INFORMATION

### COPING SUBSTRATE AND FASTENERS

THIS COPING CAN BE INSTALLED ON THE FOLLOWING SUBSTRATE USING THE FASTENERS PROVIDED BY THE MANUFACTURER .  
TYPICAL INSTALLATION ON WOOD SUBSTRATE. (TAPERED VERSION SHOWN)

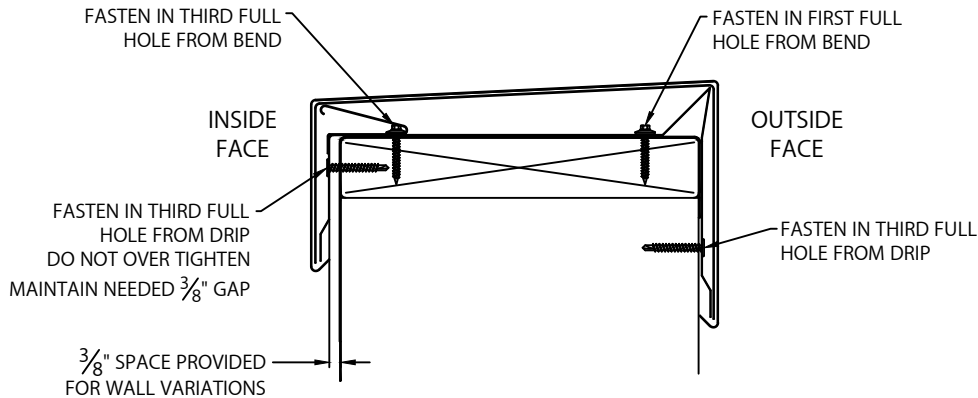

SUBSTRATE	TOP FASTENERS	FACE FASTENERS
WOOD	#10 X 1-1/2" STAINLESS STEEL SCREW	#14 X 1-1/2" PROFILER
MASONRY	1/4" X 1-1/4" TAPCON	#14 X 1-1/2" PROFILER
METAL	#12-14 X 1" TEK3	#14 X 1-1/2" PROFILER

**NOTE:** ALTERNATIVE OR UNIVERSAL FASTENERS MAY BE PROVIDED AS A SUBSTITUTE FOR THE FASTENERS LISTED BASED ON AVAILABILITY. ANY SUBSTITUTE FASTENER PROVIDED WILL BE OF EQUAL OR GREATER EQUIVALENCY.

### COPING ANCHOR CLIPS AND SPACING

ANCHOR CLIP SPACING IS DETERMINED BY THE MANUFACTURER BASED ON WALL SIZE.

#### ANCHOR CLIP DETAIL FOR WALLS GREATER THAN 14"

NOTE: ALL RADIUS COPING WILL HAVE DOUBLE SPRING ANCHOR CLIPS

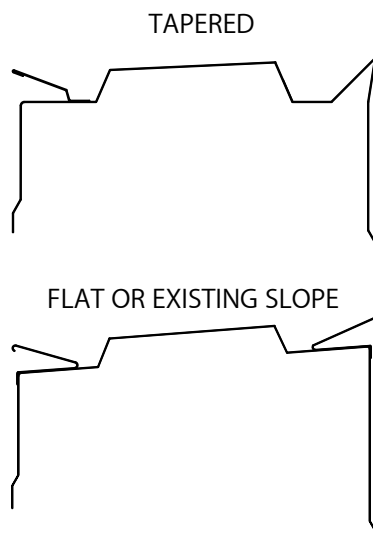

#### ANCHOR CLIP SPACING FOR STRAIGHT LENGTHS

WALL SIZE	ANCHOR CLIP SPACING
0" THRU 16"	4' - 0" O.C.
16 - 1/16" THRU 24"	3' - 0" O.C.
24-1/16" THRU 39 7/8"	2' - 0" O.C.

#### ANCHOR CLIP AND SPLICE PLATE INFORMATION FOR RADIUS COPING

WALL WIDTH	SPLICE PLATE WIDTH	ANCHOR CLIP WIDTH	ANCHOR CLIP SPACING



800-356-3521  
www.soprema.us

310 Quadral Dr.  
Wadsworth, OH 44281  
f: 330-334-6257

DATE: 12/04/24  
DRN BY: MLM  
CKD BY: MM

SHT.# 4 OF 8

DWG# 33111-44336

A

# SOPRA-TITE GOLD COPING

## INSTALLATION INSTRUCTIONS

**IMPORTANT:** PRIOR TO INSTALLATION, READ INSTRUCTIONS CAREFULLY.

**NOTE:** POSITION ROOF MEMBRANE ON TOP OF THE WALL COVERING THE TREATED WOOD NAILER(S) OR SUBSTRATE COMPLETELY. ALLOW 1/2" MINIMUM EXCESS MEMBRANE BEYOND NAILER WHERE APPLICABLE. NRCA REQUIREMENT.

**CAUTION:** INSTALL MITERS FIRST!

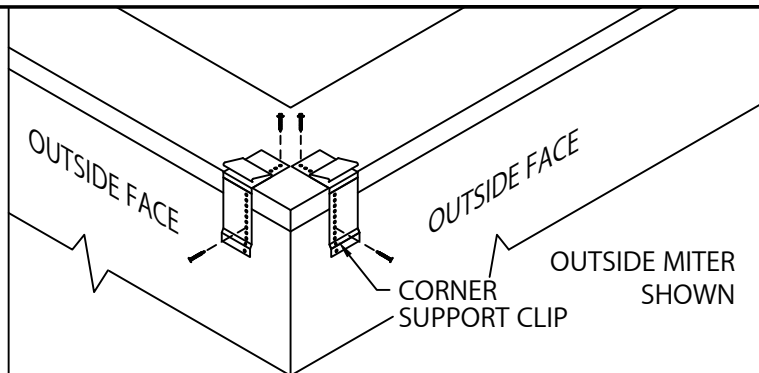

### STEP 1 - CORNER SUPPORT CLIPS

LOCATE AND FASTEN THRU GALVANIZED CORNER SUPPORT CLIP TO THE WALL AS SHOWN. FOR FASTENER DETAIL SEE PAGE 4.

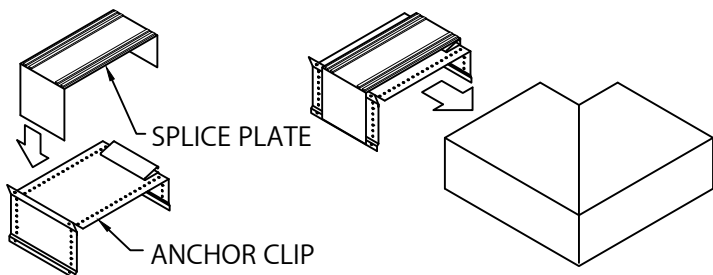

### STEP 2 - MITER SPLICE PLATES & ANCHOR CLIPS

REMOVE RELEASE PAPER FROM SPLICE PLATE SEALANT STRIPS. POSITION THE SPLICE PLATE IN THE CENTER OF THE ANCHOR CLIP. INSTALL THE SPLICE PLATE AND ANCHOR CLIP ASSEMBLIES HALFWAY INTO EACH END OF THE CORNER MITER AS SHOWN.

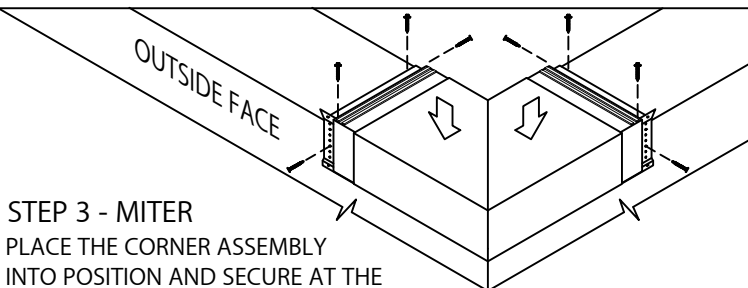

### STEP 3 - MITER

PLACE THE CORNER ASSEMBLY INTO POSITION AND SECURE AT THE EXPOSED EDGE OF THE ANCHOR CLIPS AS PER PAGE 4.

**NOTE:** REMOVE PROTECTIVE PLASTIC FILM IMMEDIATELY.

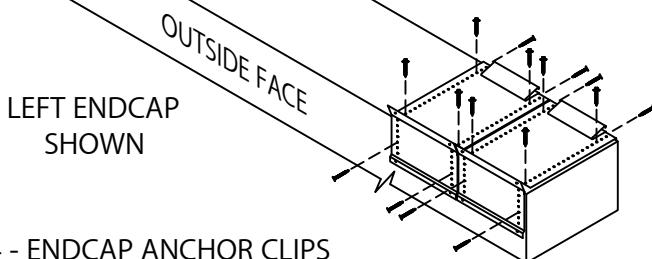

### STEP 4 - ENDCAP ANCHOR CLIPS

LOCATE AND FASTEN GALVANIZED ANCHOR CLIPS TO THE WALL WITH PROVIDED FASTENERS FOR SUBSTRATE, AS SHOWN IN DETAIL A. FOR FASTENER DETAIL SEE PAGE 4.

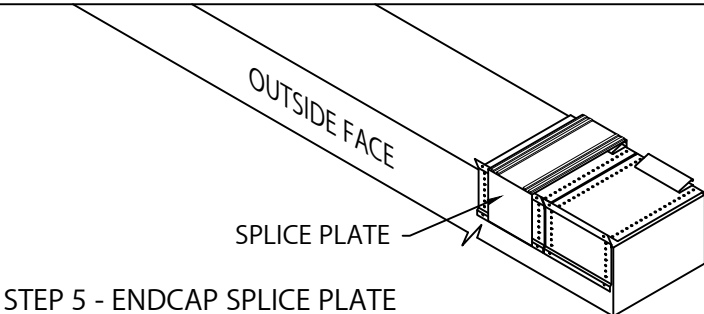

### STEP 5 - ENDCAP SPLICE PLATE

REMOVE RELEASE PAPER FROM THE TOP OF THE FACTORY APPLIED SEALANT STRIPS. PLACE THE SPLICE PLATE ONTO THE SECOND ANCHOR CLIP AS SHOWN.

### STEP 6 - ENDCAP

HOOK OUTSIDE FACE OF ENDCAP OVER THE ANCHOR CLIPS AND ROTATE INTO PLACE. ENGAGE REAR LEG ONTO ANCHOR CLIPS BY PRESSING DOWNWARD UNTIL SNAP LOCK OCCURS.

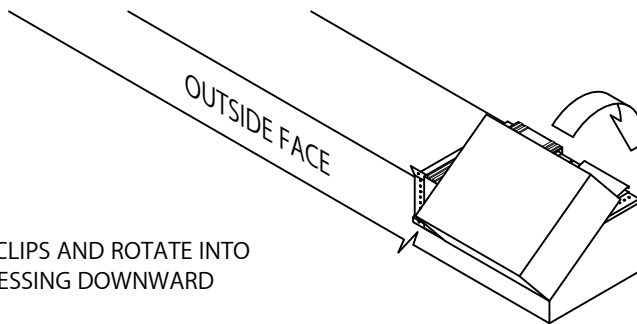

**NOTE:** REMOVE PROTECTIVE PLASTIC FILM IMMEDIATELY.



800-356-3521  
www.soprema.us

310 Quadral Dr.  
Wadsworth, OH 44281  
f: 330-334-6257

DATE: 12/04/24  
DRN BY: MLM  
CKD BY: MM

SHT.# 5 OF 8  
DWG# 33111-44336

A

# SOPRA-TITE GOLD COPING

## INSTALLATION INSTRUCTIONS

### STEP 7 - ENDWALL FLASHING COPING VERSIONS STEP 7 - 8

NOTE: WITH THIS ENDWALL FLASHING THERE ARE TWO ANCHOR CLIPS AND ONE WITH A SPLICE PLATE.

HOOK OUTSIDE FACE OF ENDCAP OVER THE ANCHOR CLIPS AND ROTATE INTO PLACE. ENGAGE REAR LEG ONTO ANCHOR CLIPS BY PRESSING DOWNWARD UNTIL SNAP LOCK OCCURS.

NOTE: REMOVE PROTECTIVE PLASTIC FILM IMMEDIATELY.

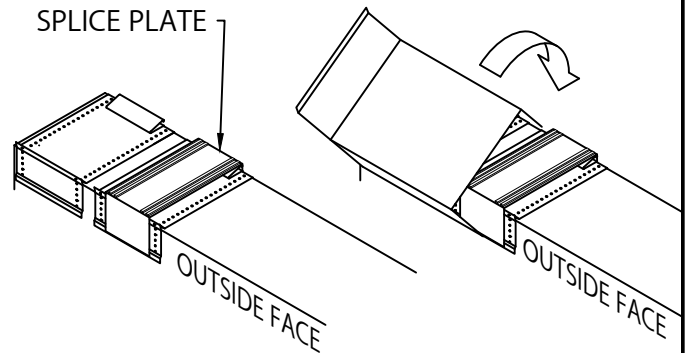

### STEP 8 - ENDWALL FLASHING

FASTEN TO WALL USING APPROPRIATE FASTENERS (BY OTHERS) AS SHOWN. APPLY NON-CURING SEALANT (BY OTHERS) TO CAULK CUP AT TOP OF FLANGE.

NOTE: REMOVE PROTECTIVE PLASTIC FILM IMMEDIATELY.

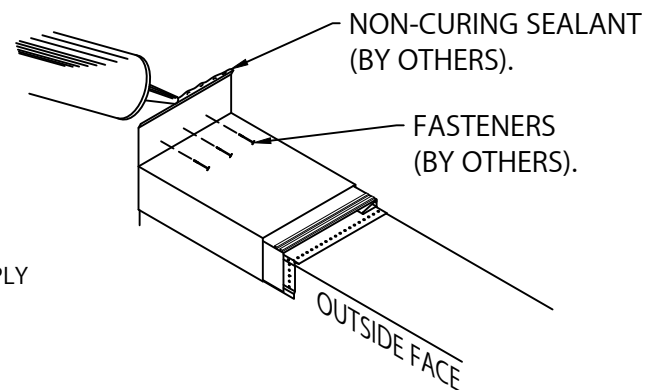

### STEP 9 - ENDWALL FLASHING SPLICE PLATE VERSION STEPS 9 - 10

NOTE: WITH THE ENDWALL FLASH SPLICE PLATE VERSION THERE IS ONE ANCHOR CLIP.

PLACE ENDWALL FLASHING ON TOP OF ANCHOR CLIP. REMOVE RELEASE PAPER FROM FACTORY APPLIED SPLICE PLATE SEALANT STRIPS. FASTEN TO WALL USING APPROPRIATE FASTENERS (BY OTHERS) AS SHOWN. APPLY NON-CURING SEALANT (BY OTHERS) TO CAULK CUP AT TOP OF FLANGE.

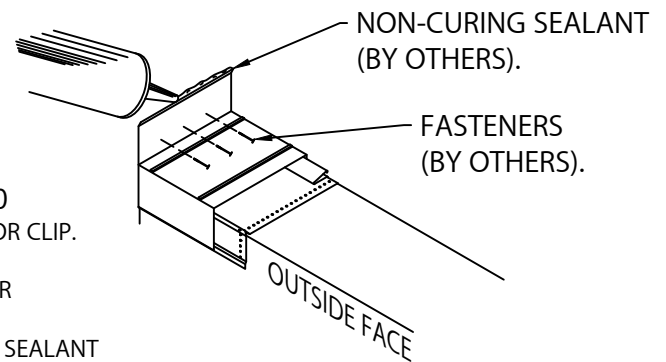

### STEP 10 - COPING

HOOK OUTSIDE FACE OF COPING OVER THE ANCHOR CLIP / ENDWALL FLASHING AND ROTATE INTO PLACE. ENGAGE REAR LEG ONTO ANCHOR CLIP BY PRESSING DOWNWARD UNTIL SNAP LOCK OCCURS.

NOTE: REMOVE PROTECTIVE PLASTIC FILM IMMEDIATELY.

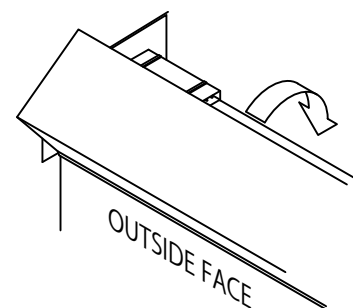

800-356-3521  
www.soprema.us

310 Quadral Dr.  
Wadsworth, OH 44281  
f: 330-334-6257

DATE: 12/04/24  
DRN BY: MLM  
CKD BY: MM

SHT.# 6 OF 8

DWG# 33111-44336

A

# SOPRA-TITE GOLD COPING

## INSTALLATION INSTRUCTIONS

OUTSIDE FACE

SEE PAGE 4

### STEP 11 - ANCHOR CLIPS

LOCATE OVER MEMBRANE AND FASTEN GALVANIZED ANCHOR CLIPS TO WALL ON CENTER WITH PROVIDED FASTENERS FOR SUBSTRATE, AS PER PAGE 4.

OUTSIDE FACE

### STEP 12 - SPLICE PLATES

PLACE SPLICE ONTO ANCHOR CLIPS AT SPLICE JOINTS 12'-0" O.C.

SPLICE PLATE

NOTE: REMOVE RELEASE PAPER FROM SEALANT STRIPS.

OUTSIDE FACE

### STEP 13 - COPING

HOOK OUTSIDE FACE OF COPING OVER THE ANCHOR CLIPS AND ROTATE INTO PLACE. ENGAGE REAR LEG ONTO ANCHOR CLIPS BY PRESSING DOWNWARD UNTIL SNAP LOCK OCCURS.

NOTE: REMOVE PROTECTIVE PLASTIC FILM IMMEDIATELY.

$\frac{3}{8}$ " SPACE

### STEP 14 - COMPLETION

CONTINUE INSTALLING COPING WITH A  $\frac{3}{8}$ " SPACE AT SPLICE JOINTS TO ALLOW FOR THERMAL EXPANSION. FIELD CUT WHERE NECESSARY USING A FINE TOOTH HACKSAW, SNIPS OR CUT-OFF WHEEL. LEAVING A CLEAN EDGE.

NOTE: REMOVE PROTECTIVE PLASTIC FILM IMMEDIATELY.



800-356-3521  
www.soprema.us

310 Quadral Dr.  
Wadsworth, OH 44281  
f: 330-334-6257

DATE: 12/04/24  
DRN BY: MLM  
CKD BY: MM

SHT.# 7 OF 8  
DWG# 33111-44336

A

# SOPRA-TITE GOLD COPING

INSTALLATION INSTRUCTIONS

## SOPRA-TITE GOLD RADIUS COPING INSTRUCTIONS

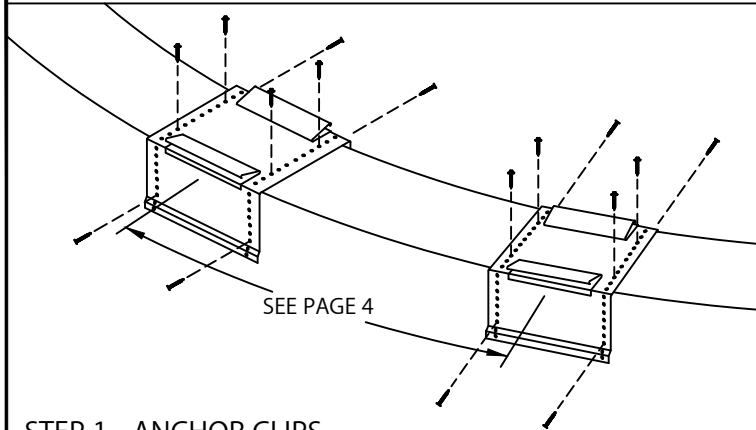

### STEP 1 - ANCHOR CLIPS

NOTE: RADIUS WILL HAVE DOUBLE SPRING ANCHOR CLIPS. ANCHOR CLIPS WIDTH WILL BE DETERMINED BY RADIUS SIZE AND MATERIAL. LOCATE AND FASTEN ANCHOR CLIPS WITH PROVIDED FASTENERS FOR SUBSTRATE. SEE PAGE 4, AND ANCHOR CLIP SPACING.

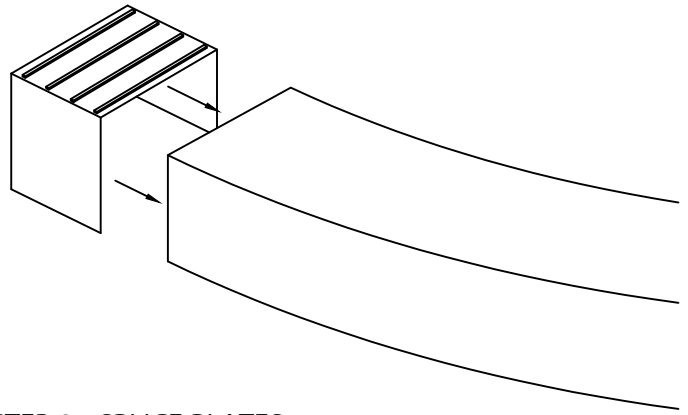

### STEP 2 - SPLICE PLATES

NOTE: ANCHOR CLIPS WIDTH WILL BE DETERMINED BY RADIUS SIZE AND MATERIAL. ALL SPLICE PLATES ARE PROVIDED. REMOVE RELEASE PAPER LEFT TWO SEALANT STRIPS. INSERT SPLICE PLATE HALFWAY INTO THE RIGHT END OF RADIUS SECTION.

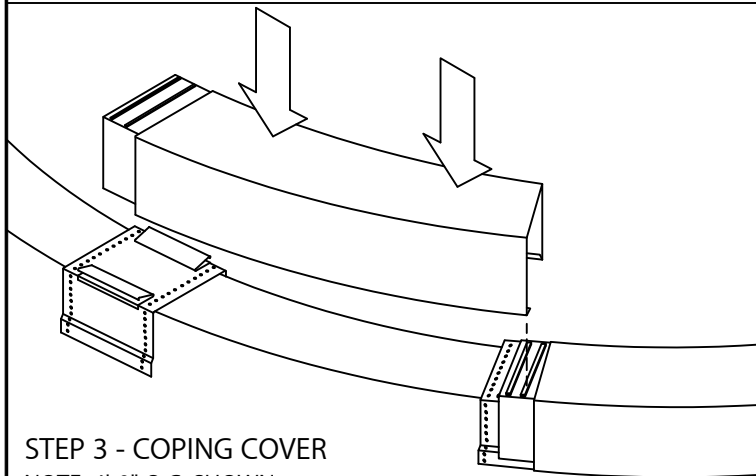

### STEP 3 - COPING COVER

NOTE: 4'-0" O.C. SHOWN.  
REMOVE RELEASE PAPER FROM RIGHT TWO FACTORY APPLIED SEALANT STRIPS ON THE SPLICE PLATE ON THE COPING SECTION. INSTALL RADIUS COPING SECTIONS FROM LEFT TO RIGHT. PLACE COPING INTO POSITION AND PRESS DOWNWARD UNTIL SNAP-LOCK OCCURS.

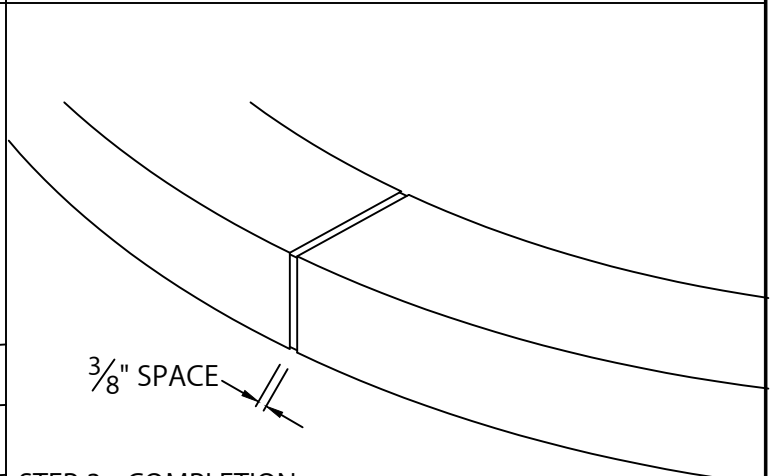

### STEP 3 - COMPLETION

USING RADIUS SECTIONS TO COVER ALL EXPOSED CLIPS / SPLICES, CUT TO LENGTH AS NEEDED USING A FINE TOOTH HACKSAW, SNIPS, OR CUT-OFF WHEEL LEAVING A CLEAN EDGE. BE SURE TO LEAVE A 3/8" SPACE AT EACH JOINT.

NOTE: REMOVE PROTECTIVE FILM IMMEDIATELY.



800-356-3521  
www.soprema.us

310 Quadral Dr.  
Wadsworth, OH 44281  
f: 330-334-6257

DATE: 12/04/24  
DRN BY: MLM  
CKD BY: MM

SHT.# 8 OF 8  
DWG# 33111-44336

A